

**A better  
view  
of the world**



## **MeoPro R6**

User manual

EN



**CZ** NIKDY SE NEDÍVEJTE OPTICKÝM  
PŘÍSTROJEM PŘÍMO DO SLUNCE!

**EN** NEVER LOOK DIRECTLY AT THE SUN  
THROUGH THE DEVICE!

**DE** SCHAUEN SIE NIEMALS DURCH DAS  
OPTISCHE GERÄT DIREKT IN DIE SONNE!

**FR** NE JAMAIS UTILISER LE DISPOSITIF OPTIQUE  
POUR REGARDER LE SOLEIL DIRECTEMENT !

**IT** NON GUARDARE MAI DIRETTAMENTE IL SOLE  
ATTRAVERSO LO STRUMENTO OTTICO!

**ES** NUNCA MIRE AL SOL DIRECTAMENTE MEDIANTE  
NINGÚN TIPO DE INSTRUMENTO ÓPTICO!

**PT** NUNCA OLHE DIRETAMENTE PARA O SOL COM  
O DISPOSITIVO ÓPTICO!

**RU** НИКОГДА НЕ СМОТРИТЕ В ОПТИЧЕСКИЙ  
ПРИБОР ПРЯМО НА СОЛНЦЕ!



**Dear customer,**

All optical devices manufactured and sold by Meopta s.r.o. are produced using the latest technology and standards and offer users long-term satisfaction.

To ensure a reliable, trouble-free service life, Meopta s.r.o. takes this opportunity to provide you with detailed information on the functions, maintenance and safe use of the optical device you have purchased.

**Before installing and using the optical device, please study this manual carefully.**

In the event of a complaint or defect, contact your dealer or Meopta s.r.o. directly. Information on our products, news and dealers can be found at [www.meoptasportsoptics.com](http://www.meoptasportsoptics.com).

**RECOMMENDATIONS FOR A NEW RIFLE SCOPE MOUNTING**

A quality mount is very important to perfect operation of every optical device, including rifle scopes, regardless of their size and optical parameters. Therefore, when choosing a mount, special attention must be paid to its parameters and quality of workmanship.

**When choosing a rifle scope mount, we recommend sticking to proven, high-quality manufacturers and entrusting actual adjustment, including subsequent rectification (aiming) to a professional, preferably a gunsmith, armourer, or an experienced shooter with theoretical knowledge and practical skills.**

A poor-quality mounting with unprofessional adjustment of the optical device is one of the main causes of unsatisfactory results when rectifying a rifle scope and aligning the optical axis of the rifle scope with the axis of the weapon system barrel. In some cases, it can lead to irreversible mechanical damage to the rifle scope, which not only makes the optical device unreliable, but also voids the manufacturer's warranty.



#### **ANTI-REFLECTIVE COATINGS**

The special anti-reflective coatings provide light transmission up to 90%.



#### **WATER-REPELLENT COATINGS**

External optical surfaces have a special hydrophobic coating.



#### **NITROGEN-FILLED**

The rifle scopes are sealed and filled with inert nitrogen gas, which provides reliable protection against fogging.



#### **WATERPROOF**

The rifle scopes are completely waterproof, even when fully immersed in water, and are fully protected against moisture, rain and snow.



#### **SHOCK RESISTANT**

The mechanical design of the rifle scopes provides maximum shock resistance, making them suitable for all common types of weapons.



#### **QUADRATIC COURSE OF RECTIFICATION**

Horizontal and vertical movement of the reticle during adjustment are independent of each other. The **pop-up function** is useful against unintentional rotation of the rectification knobs. In the pushed-in position, they are locked and cannot be turned.



#### **ANODIZED SURFACE**

A special abrasion-resistant coating eliminates glare.



#### **BRILLIANT IMAGE**

Maximum resolution and contrast with precise colour representation throughout the field of view.



#### **ALUMINIUM TUBE**

The one-piece main tube made of aircraft-grade aluminium alloy guarantees durability and long-lasting service life.



#### **DIFFERENT AIMING RETICLES**

Different aiming reticles are available.



#### **ADJUSTABLE ZOOM**

The MeoPro R6 range of rifle scopes includes models with adjustable zoom in a maximum to minimum range of 6:1.



#### **6 LEVELS OF LIGHTING**

Six levels of light intensity with switching between positions.



#### **AUTO OFF**

The lighting will turn off after about 3 hours of operation.

## ▼ DEVICE DESCRIPTION

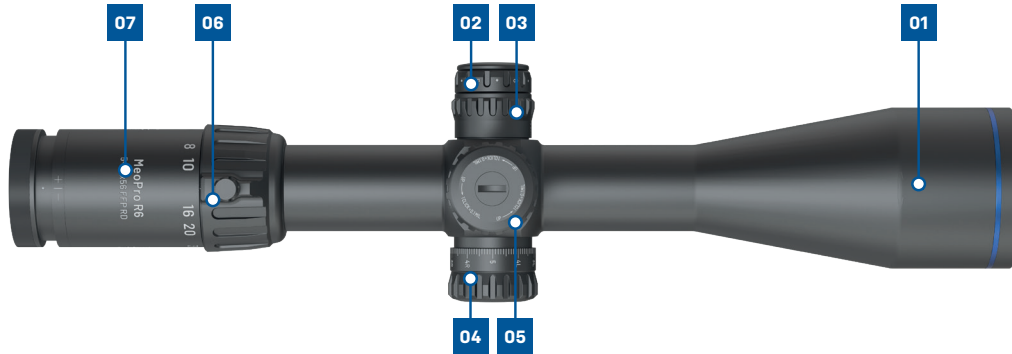

- 01. Objective lens
- 02. Illuminator <sup>(a)</sup>
- 03. Lens focus knob – parallax <sup>(b)</sup>
- 04. Horizontal rectification dial
- 05. Vertical rectification dial
- 06. Magnification adjustment sleeve
- 07. Eyepiece with focusing sleeve

Devices with aiming reticle illumination:

**MeoPro R6 1-6x24 SFP RD**  
**MeoPro R6 2.5-15x44 SFP RD**  
**MeoPro R6 3-18x50 SFP RD**  
**MeoPro R6 3-18x50 FFP RD**  
**MeoPro R6 3-18x56 FFP RD**  
**MeoPro R6 4.5-27x50 SFP RD**  
**MeoPro R6 4.5-27x50 FFP RD**  
**MeoPro R6 5-30x56 FFP RD**

Devices without aiming reticle illumination:

**MeoPro R6 2.5-15x44 SFP**  
**MeoPro R6 3-18x50 SFP**

Rifle scopes of the **MeoPro R6** series are used as a complement to various hunting firearms. The rifle scope creates a magnified, horizontal and vertical image of the observed target and, in conjunction with a firearm, multiplies shooting precision at longer distances. Filled with inert gas, the rifle scopes are designed to be 100% water-proof and dust-proof.

**▼ CAUTION: NEVER USE THE DEVICE TO LOOK DIRECTLY INTO THE SUN! This can damage your sight.**

(a) models with the RD designation

(b) models 1-6x24 with differing availability

## ▽ RECTIFICATION MECHANISM

The rectification knobs allow precise step adjustments with excellent repeatability, extended range and maximum accuracy. Distinctive audible clicks allow for accurate adjustment even under field conditions.

### Rectification knob variants by device type:

#### Low knob

1-6x24 SFP RD – 4C  
 1-6x24 SFP RD – K-Dot 2  
 2.5-15x44 SFP RD – 4C  
 2.5-15x44 SFP – Z-Plex



#### Vertical high

3-18x50 SFP RD – 4C  
 3-18x50 SFP – Z-Plex  
 3-18x50 FFP RD – Mrad 1 RD  
 3-18x56 SFP RD – 4C  
 3-18x56 SFP RD – BDC 3



#### Both high

1-6x24 SFP RD – BDC 3  
 4.5-27x50 SFP RD – 4C  
 4.5-27x50 FFP RD – Mrad 1 RD  
 5-30x56 FFP RD – Mil-Dot 3  
 5-30x56 FFP RD – Mrad RD



### Perform the correction as follows:

On the version without caps, pull out the knob with a click so that it can be turned in steps – **pop-up function**.

The **pop-up function** is useful against unintentional rotation of the knobs. In the pushed-in position, they are locked and cannot be turned.



## ▽ POINT OF IMPACT CORRECTION



► Movement of mean point of impact  
**upward**

- turn the side dial control  
correction toward "UP" arrow



► movement of mean point of impact  
**downward**

- turn the side dial control  
correction against "UP" arrow

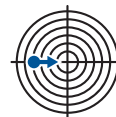

► Movement of mean point of impact  
**rightward**

- turn the side dial control  
correction toward "R" arrow



► Movement of mean point of impact  
**leftward**

- turn the side dial control  
correction against "R" arrow

## ▼ ZEROSTOP FUNCTION

This function can be used only with height (vertical) rectification. You can use the setting to the desired value by the sight-in, and after each rectification adjustment you can return to that position. For horizontal rectification, only setting of a sight-in value of "0" to the mark on the rectification knob is possible.

### Procedure

- To set the function, it is first necessary to unscrew the cap (depending on device type). The HEIGHT CORRECTION KNOB (09) MUST BE SET TO THE UNLOCKED POSITION (pushed out) – the "pop-up" function!
- Unscrew the central screw (08), remove the knob (09).
- Loosen the three locking screws (11) of the adjusting ring with the mandrel (10) using a 1.3 Allen wrench.
- After they have been loosened, the adjustment ring can be turned without affecting the rectifier setting. Move the ring pin to the catch (12) by turning it clockwise. After turning it to this position, tighten the three screws to ensure the "zerostop" function is set.
- Then put the knob (09) back in place, set it to 0 and install the central screw (08).
- Lock the knob by moving it downward and, if necessary, screw on the rectification knob cap.

### Warning

If, after the knob (09) is removed, one of the locking screws (11) is in alignment with the catch (12). It is necessary to put the knob (09) back on the rectification mechanism and make a correction of approximately 5 clicks counterclockwise. This must then be taken into account when adjusting the mandrel on the adjusting ring (10). By moving it about 5 clicks, all three locking screws are made accessible and the procedure is then identical to the case when these screws were accessible.

It is important that when adjusting the mandrel as in the first case, this mandrel does not come into contact with the catch, but is set in front of it by a distance corresponding to about 5 clicks. This will reset the five-click shift to reveal the inaccessible screw.

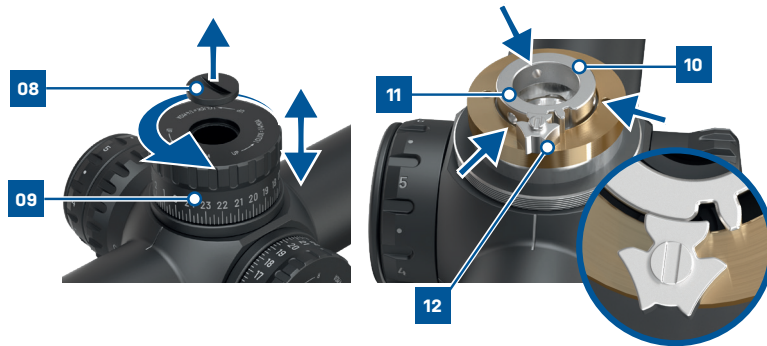

## ▼ ZERO RESET

Pull out the vertical or horizontal adjustment knobs until they click; then loosen the centre screw with a coin. Slide the knob out a little, so that it turns freely, set the mark on the knob against the mark on the tube, and reinsert. Screw the knob's screw back in.



## ▼ ILLUMINATOR

The reticle illumination function enables the user to select illumination brightness levels. It enables you to set 6 levels of lighting intensity according to the scale by turning the illuminator socket with half-click on/off positions.

**Before first use,** unscrew the cap (08) (the coin slot is for this). Insert the CR2032 3V battery with the polarity correctly oriented, positive pole facing up, and screw the illuminator cap back on.

**Caution:** Make sure that the sealing ring on the cap is correctly installed. An incorrectly screwed-on cap or sealing ring may result in a non-functional illuminator.



## ▼ BATTERY REPLACEMENT

Proceed the same as when first inserting a battery into the device.

**Attention:** Dispose of used batteries according to the Disposal Instructions.



**Caution:** Keep button batteries out of the reach of children – they may swallow them. Make sure that children cannot reach batteries in open packages.

The scope is equipped with an auto-off function after approximately 3 hours of operation if no changes are made to the reticle brightness setting during this time.

## ▽ DIOPTRIC CORRECTION

### Focusing the aiming reticle

The focusing eyepiece (07) allows the user to correct for eye defects and focus the reticle. Look through the rifle scope at a light background and turn the eyepiece until the reticle is sharp.



## ▽ DEVICE MAGNIFICATION

Variable magnification – or zoom – allows the user to adjust the device with the magnification sleeve (06) according to the user's needs; it is easily adjustable. Current magnification is indicated by a line.

For shooting at short distances or in limited spaces, low to medium zoom is appropriate. For shooting at greater distances, choose greater magnification.



## ▽ PARALLAX ADJUSTMENT

### What is parallax?

Parallax is an optical phenomenon where the reticle in a rifle scope appears to move relative to the target when you move your head. This happens when the target and reticle are not in the same focal plane.

### Why is parallax correction important?

When the parallax is properly set, the reticle stays in place even if you move your head. This means that your shots will be more precise, because the target and the reticle are in the same focal plane.

### Lens focus knob control parallax correction (03)

It is continuous, with stops at the minimum and maximum values. The knob is placed on the same axis as the central cube and is integrated with the illuminator knob. The position is indicated by a line on the central cube.



## ▼ USING THE RETICLE

The reticle is used to achieve accurate aim. The reticle in MeoPro R6 rifle scopes is located either in the first focal plane (FFP) or second focal plane (SFP) marked on the rifle scope.

With the reticle placed in the first focal plane, the subjective size of the image changes when zooming in/out.

With the reticle placed in the second focal plane, the subjective size of the image doesn't change.

For the basic rifle scopes, the reticles offered are listed in the table.

An overview of reticles and their use in each of the devices can be found at [www.meoptasportsoptics.com](http://www.meoptasportsoptics.com).

**FFP**  
first focal plane  
in the first focal plane

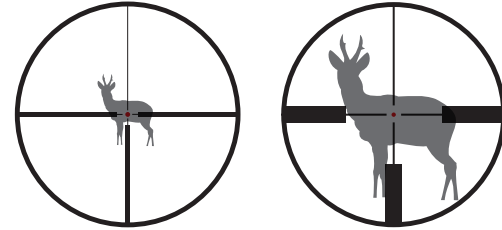

**SFP**  
second focal plane  
in the second focal plane

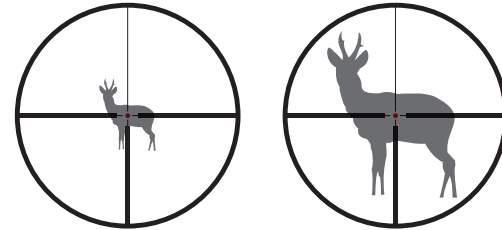

**AIMING RETICLE**

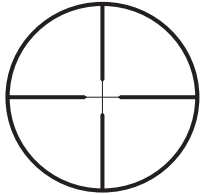

Z PLEX

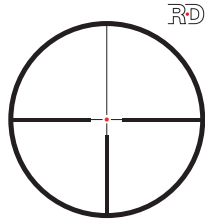

4C

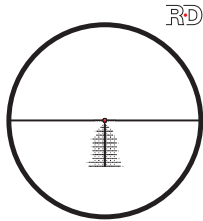

MRAD 1 RD

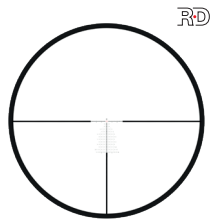

MRAD RD

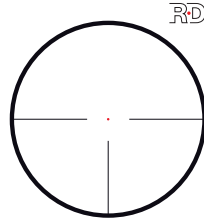

KDot 2

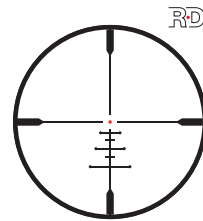

BDC 3

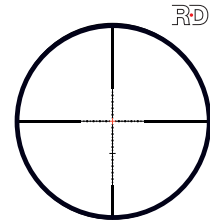

MilDot 3

	Z-Plex	4C	KDOT 2	BDC 3	MIL-DOT 3	MRAD 1 RD	MRAD RD
1-6x24 SFP RD		•	•	•			
2.5-15x44 SFP RD		•					
2.5-15x44 SFP	•						
3-15x50 SFP RD		•					
3-15x50 SFP	•						
3-15x50 FFP RD						•	
3-15x56 SFP RD		•		•			
4.5-27x50 SFP RD		•					
4.5-27x50 FFP RD						•	
5-30x56 FFP RD					•		•

## ▼ TECHNICAL SPECIFICATIONS

		1-6x24 RD		2.5-15x44 2.5-15x44 RD		3-18x50 3-18x50 RD		3-15x56 RD		4.5-27x50 RD		5-30x56 RD	
Magnification		1x	6x	2.5x	15x	3x	18x	3x	18x	4.5x	27x	5x	30x
Optical diameter of objective lens	mm	24		44		50		56		50		56	
Output pupil diameter	mm	10	4	11	2.9	9.5	2.8	9.5	3.1	9.5	1.9	9.5	1.9
Eye relief	mm	90		90		90		90		90		90	
Field of view	°	20.7	3.6	7.6	1.3	6.4	1.1	6.3	1.1	4.2	0.7	4.7	0.7
	m/100m	36.5	6.3	13.3	2.3	11.2	1.9	11.1	1.9	7.3	1.2	8.2	1.2
Dioptric range of eyepiece	dpt	+2 / -2		+2 / -2		+2 / -2		+2 / -2		+2 / -2		+2 / -2	
Rectification step	MIL	0.15		0.075		0.075		0.075		0.075		0.075	
	MOA	0.5		0.25		0.25		0.25		0.25		0.25	
	cm/100m	1.5		0.7		0.7		0.7		0.7		0.7	
Rectification range	MIL	34.9		20.4		26.2		26.2		24.4		32	
	MOA	120		70		90		90		84		110	
	cm/100m	349		204		262		262		244		320	
Parallax adjustment	yds	10 -∞*		10 -∞		10 -∞		10 -∞		25 -∞		25 -∞	
Weight (without covers, with battery)	g	628/650*		772/822		850/900		915		935		1080	
Focal position of reticle		2		2		2/1		2		2/1		1	

\* functionality available with BDC3 aiming reticle type, with heavier weight

## TECHNICAL SPECIFICATIONS

Anglo-American units

		1-6x24 RD		2.5-15x44 2.5-15x44 RD		3-18x50 3-18x50 RD		3-15x56 RD		4.5-27x50 RD		5-30x56 RD	
Magnification		1x	6x	2.5x	15x	3x	18x	3x	18x	4.5x	27x	5x	30x
Optical diameter of objective lens	mm	24		44		50		56		50		56	
Output pupil diameter	in	0.39	0.16	0.43	0.11	0.37	0.11	0.37	0.12	0.37	0.07	0.37	0.07
Eye relief	in	3.9		3.9		3.9	3.6	3.9	3.6	3.9		3.9	
Field of view	°	20.7	3.6	7.6	1.3	6.4	1.1	6.3	1.1	4.2	0.7	4.7	0.7
	ft/100yd	109.5	18.8	39.8	6.8	33.5	5.8	33	5.8	22	3.6	24.6	3.6
Dioptric range of eyepiece	dpt	+2 / -2		+2 / -2		+2 / -2		+2 / -2		+2 / -2		+2 / -2	
Rectification step	MIL	0.15		0.075		0.075		0.075		0.075		0.075	
	MOA	0.5		0.25		0.25		0.25		0.25		0.25	
	in/100yd	0.52		0.26		0.26		0.26		0.26		0.26	
Rectification range	MIL	34.9		20.4		26.2		26.2		24.4		32	
	MOA	120		70		90		90		84		110	
	in/100yd	126		73		94		94		88		115	
Parallax adjustment	yds	10 -∞*		10 -∞		10 -∞		10 -∞		25 -∞		25 -∞	
Weight (without covers, with battery)	oz	22.1 / 22.3*		27.2 / 28.9		29.9 / 31.7		32.2		33		38	
Focal position of reticle		2		2		2 / 1		2		2 / 1		1	

\* functionality available with BDC3 aiming reticle type, with heavier weight

## ▼ DIMENSIONS

		1-6x24	2.5-15x44	3-18x50	3-18x56	4.5-27x50	5-30x56
A	mm	256	355	371	368	361	392
B	mm	159	136	142	138	136	160
C	mm	72	45	46	44	53	58
D	mm	47	52	56	55	43	61
E	mm	30	51.5	58	64	57.5	63.5
F	mm	46.5	43.5	43.5	43.5	43.5	46.5
G	mm	30	30	30	30	30	34
H	mm	-	113	119	120	120	126
K	mm	96	106	110	110	105	106

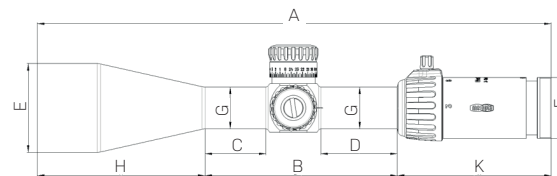

## ▼ DIMENSIONS

Anglo-American units

		1-6x24	2.5-15x44	3-18x50	3-18x56	4.5-27x50	5-30x56
A	in	10.08	10.04	14.61	14.49	14.21	15.43
B	in	6.26	5.35	5.59	5.43	5.35	6.30
C	in	2.83	1.77	1.81	1.73	2.09	2.28
D	in	1.85	2.05	2.20	2.17	1.69	2.40
E	in	1.18	2.03	2.28	2.52	2.26	2.50
F	in	1.83	1.71	1.71	1.71	1.71	1.83
G	in	1.18	1.18	1.18	1.18	1.18	1.34
H	in	-	4.45	4.69	4.72	4.72	4.96
K	in	3.78	4.17	4.33	4.33	4.13	4.17

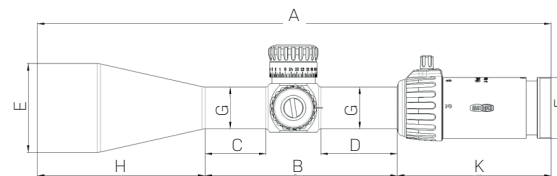

## ▼ MAINTENANCE AND CLEANING

All **MeoPro R6** rifle scopes feature a robust dust-proof and water-proof design but, like any other optical-mechanical devices, require careful handling and protection of optical surfaces against damage. When the rifle scope is not being used, its outer optical surfaces should be protected with the supplied caps. Dust deposits on the mechanical parts of the binocular should be removed with a soft cloth. Dust on the optical parts should be blown off or wiped off gently with an anti-static cloth supplied with the binocular.

After using the rifle scope in rain, thorough drying with a soft cloth is recommended. Be sure to store any optical products in a dry, ventilated area; if stored in extremely humid or tropical conditions, place the product in its case together with a desiccant, e.g. silica gel.

## ▼ INCLUDED IN PACKAGE

1x	Rifle scope
1x	Objective lens and eyepiece caps
1x	Battery Li 3V CR2032
1x	Key to battery cover, rectification
1x	1.3 Allen wrench for adjustment ZEROSTOP
1x	Optical wipe
1x	User manual

## ▼ RECOMMENDED ACCESSORIES

Sunshade  
Ring mounting

## **DISPOSAL INSTRUCTIONS**

### **IMPORTANT:**

**INSTRUCTIONS FOR DISPOSING OF THE PRODUCT AT THE END OF ITS USEFUL LIFE.**

### **BATTERIES**

Never discard batteries with municipal waste. The end user must take dead batteries to a recycling location (e.g. technical service, electrical appliance store) or to the electrical equipment collection site near his home.

### **CONFORMITY**

The products conform to European Union directives 2004/108/EU, 2011/65/EU and 2012/19/EU.

### **PRODUCT**

Do not discard the product with mixed municipal waste. This waste must be discarded as used electrical equipment. Discarded electrical equipment must be taken free of charge to a REMA company collection facility. The manufacturer has a contract with this company within the municipal system.



*The images used in this manual are for illustration only and may differ slightly from the product you have purchased.*

MeoPro R6 – EN – 1082051 – rev. A

Versions in more languages can be found at:

**[www.meoptasportsoptics.com](http://www.meoptasportsoptics.com)**



## **Meopta s.r.o.**

Kabelikova 1  
Pferov 750 02  
Czech Republic  
tel. +420 581 241 111  
[www.meopta.com](http://www.meopta.com)

